

Front Suspension

Ride Height: _____
 Camber: _____
 Toe: _____
 Anti-Roll Bar: _____
 Arm Type: _____
 Tower Type: _____
 Wheelbase Shim: _____
 Wheel Hex: _____
 Caster Block: 8° 9° 10°
 Chassis Brace Support: _____
 Top Plate Brace: _____
 Front Axles: CVA DCV

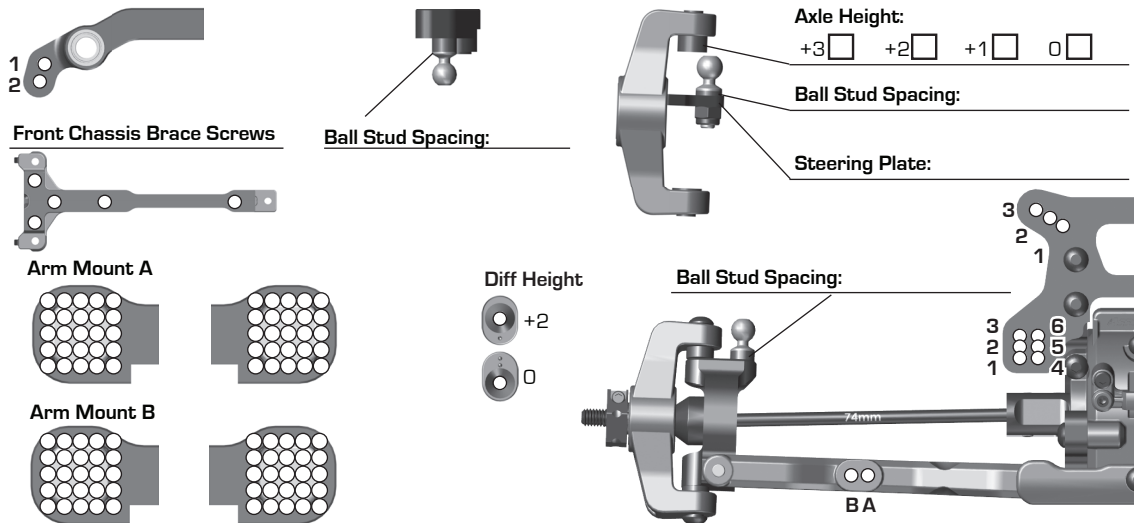

Notes

Rear Suspension

Ride Height: _____
 Camber: _____
 Anti-Roll Bar: _____
 Arm Type: _____
 Wheelbase Shim: _____
 Wheel Hex: _____
 CVA Bone Length: _____
 Chassis Brace Support: _____
 Hub Spacing: Fwd Mid Back

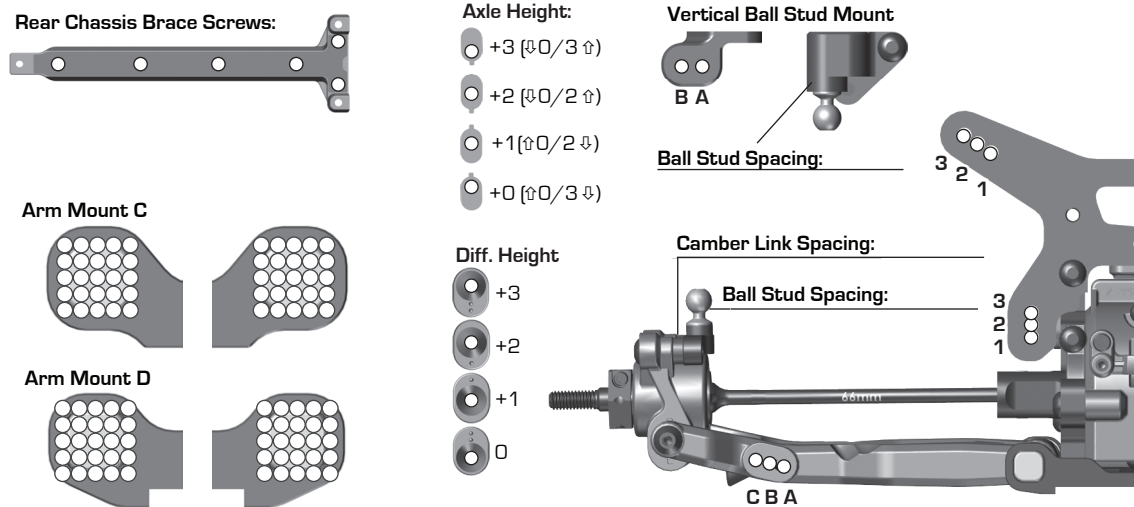

Notes

Electronics, Drivetrain

Radio: _____ Servo: _____
 EPA: Throttle: _____ % Brake: _____ %
 ESC: _____
 ESC Settings: _____
 Motor: _____ Timing: _____
 Pinion: _____ Spur: _____
 Battery: Back 1 2 3 4 Fwd
 Battery Position: _____

Diffs	Front	Center	Rear
Fluid			
Gears			
Type			

Notes

Slipper Clutch: _____
 # of Pads _____

Shocks	Front	Rear
Piston:		
Fluid:		
Spring:		
Limiters:	Int: _____ Ext: _____	Int: _____ Ext: _____
Stroke:		
Eyelet Length:		
Cup Offset:		

Notes



Track Info, Tires & Aero

Layout: Tight Mixed Open Extra Large
 Surface: Dirt Carpet Astroturf
 Traction: Low Medium High Very High
 Moisture: Dry Damp Wet
 Condition: Indoor Outdoor Dusty Hard Packed
 Bumpy Grooved Smooth Loamy
 Temperature: Ambient: _____ Humidity: _____

Notes

Front Tires: _____
 Front Compound: _____
 Front Insert: _____
 Rear Tires: _____
 Rear Compound: _____
 Rear Insert: _____
 Wheel (F/R): _____

Notes

Body: _____
 Rear Wing: _____
 Wing Angle: 0° 6°
 Wing Mount Height: 0 -2
 Front Wing Yes No
 Servo Weights: _____
 Electronic Weights: _____
 Total Vehicle Weight: _____

Comments